

# Stationary concrete pump

**BSA 1405 E**

**BSA 1408 E**

Output up to 79 m<sup>3</sup>/h

Delivery pressure up to 106 bar

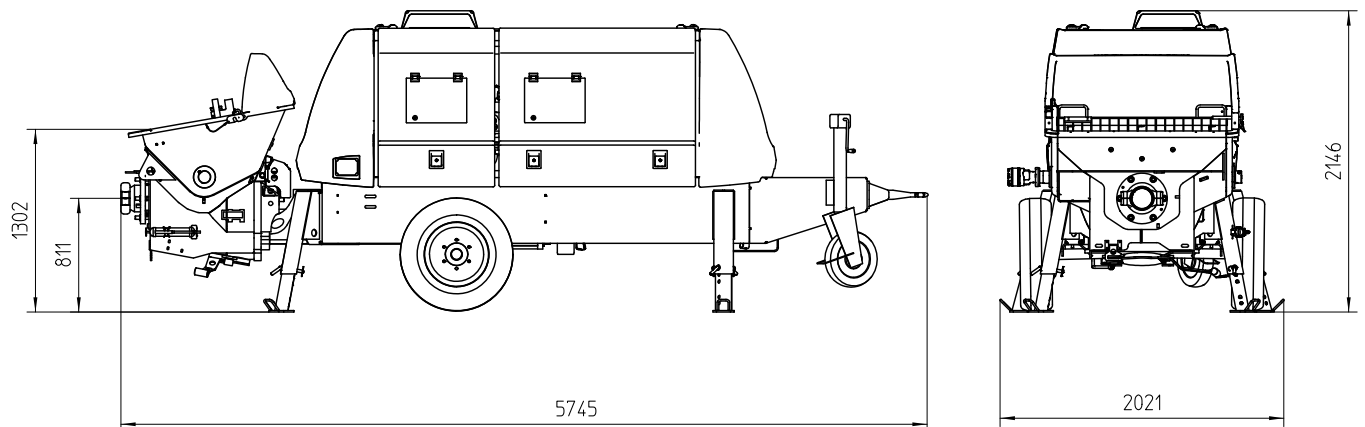

Note: Standard version. Dimensions and weights depend on equipment. Subject to technical modifications and errors.

## Technical data

Model		BSA 1405 E	BSA 1408 E
Material number		102390.000	102403.000
Output	m <sup>3</sup> /h	55 / 37 *	79 / 53 *
Delivery pressure	bar	71 / 106 *	
Delivery cylinder	Ø mm	200	
Delivery cyl. stroke	mm	1400	
Strokes / minute		21 / 14 *	30 / 20 *
Engine / motor power	kW	75	110
Hopper		RS 909	
Capacity	l	approx. 600	
Filling height	m	approx. 1.3	
Transfer tube		S 2015 D	
Line connection	mm	SK 125	
Pressure connection	"	5.5	
Control system		EPS FFH	
Weight	kg	4600	

\* Values for hydraulic fluid being fed to piston-side  
All data maximum theoretical

## Serial equipment

Agitator safety switch off	Electronic error management
Cable remote control 10 m	Ergonic Graphic Display (EGD)
Central lubrication on hopper with hand lever press	Flushing water pump 50 l/min 20 bar
Cleaning accessories	Gate valve connection
Coloring: Pump, frame, roof, tank and hood anthracite-grey Cover chrome yellow	Grill 70 mm
Concrete hopper with agitator	Operating manuals (1× paper, 1× CD-ROM) spare part list
Concrete output adjust (BSA 1408 E)	Outriggers 4× mech.
Concrete pressure adjust (BSA 1408 E)	Pump flow meter (BSA 1408 E)
Coupling ring (DIN)	Splash guard
Drive electric 110 kW (BSA 1408 E)	Support wheel
Drive electric 75 kW (BSA 1405 E)	Tool set incl. standard equipment
	Trailer F8, travelling in site

See quotation for exact serial delivery scope.  
Comprehensive range of options available on request.